

# DW10 FU (C/D/E)

EURO 6 step 1 Diesel Engine  
L.C.V. application version



1997 cm<sup>3</sup>  
4 cylinders in-line  
120 kW (163 hp) max @ 3750 rpm  
350 Nm max @ 1750 rpm  
4 valves per cylinder  
Turbocharged  
2 camshafts  
Weight\*: 180 kg  
\*Weight with oil and clutch without accessories

Performances curves

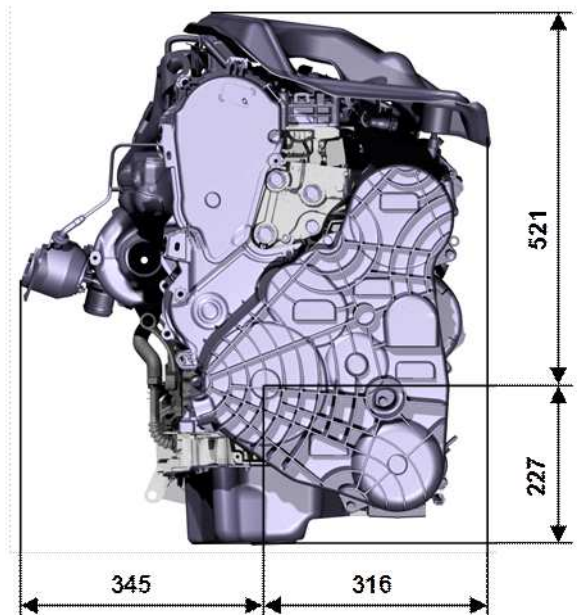
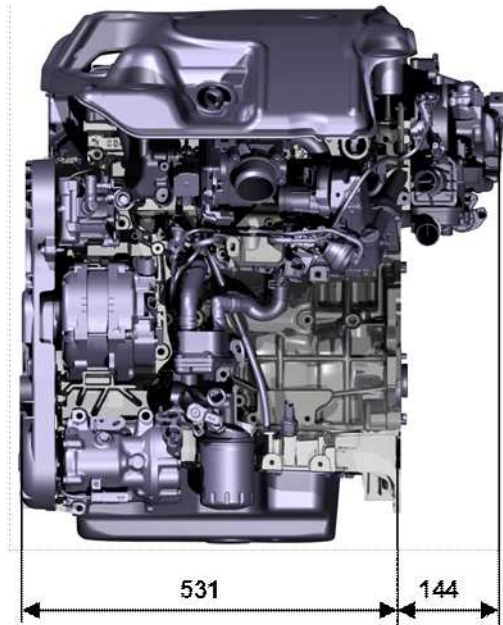
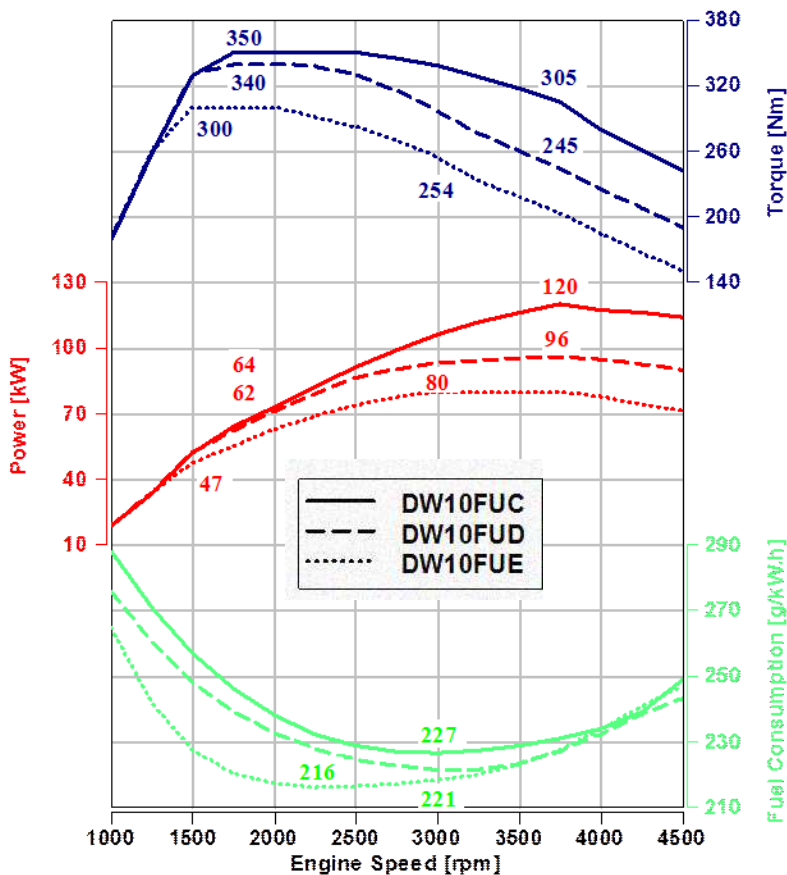

Last update 10/04/17

All specifications may be subject to modification without notice

# DW10 FU (C/D/E)

EURO 6 step 1 Diesel Engine  
L.C.V. application version



## General Technical Characteristics

<b>Name</b>	DW10 FU (C/D/E)
<b>Fuel</b>	Diesel
<b>Base engine weight</b>	180 kg
<b>Displacement</b>	1997 cm <sup>3</sup>
<b>Bore</b>	85 mm
<b>Stroke</b>	88 mm
<b>Engine architecture</b>	4 cylinders in-line
<b>Number of camshafts</b>	2
<b>Balance shaft</b>	No
<b>Compression ratio</b>	16.7/1
<b>Piston rod centreline distance</b>	145 mm
<b>Maximum rotation</b>	5000 rpm
<b>Idle rotation</b>	750 rpm
<b>Injection system</b>	Delphi DCM6.2
<b>High pressure pump</b>	Delphi DFP 6.1E
<b>Injector</b>	Delphi
<b>Turbocharger</b>	VGT (BWTS)
<b>EGR valve</b>	Yes
<b>EGR cooler</b>	Yes
<b>Intercooler</b>	Yes
<b>Catalyst</b>	Yes
<b>DPF</b>	Yes
<b>SCR</b>	Yes with 1 downstream NOx sensor
<b>Coolant liquids</b>	Brugarolas Bradol 497 (dilution 50%) Arteco Freecor DSC (dilution 50%)
<b>Water temperature criteria</b>	112°C for continuous (95%) 115°C for peak (4%) 118°C for exceptional (1%)
<b>Oil temperature criteria</b>	125°C for continuous 145°C for peak (5%)
<b>Oil capacity</b>	6.6 L
<b>Standard Installation</b>	E/W and 4° forward (Intake side)

Last update 10/04/17

All specifications may be subject to modification without notice